

SECTION E

THE CLUTCH

Description.

Section No. E.1 Adjustment.

Section No. E.2 Removing the clutch.

Section No. E.3 Dismantling the clutch.

Section No. E.4 Assembling the clutch.

Section No. E.5 Adjusting the release levers.

Section No. E.6 Refitting the clutch.

Section No. E.7 Servicing the clutch.

Section No. E.8 Clutch withdrawal lever pivot bolt.

THE CLUTCH COMPONENTS

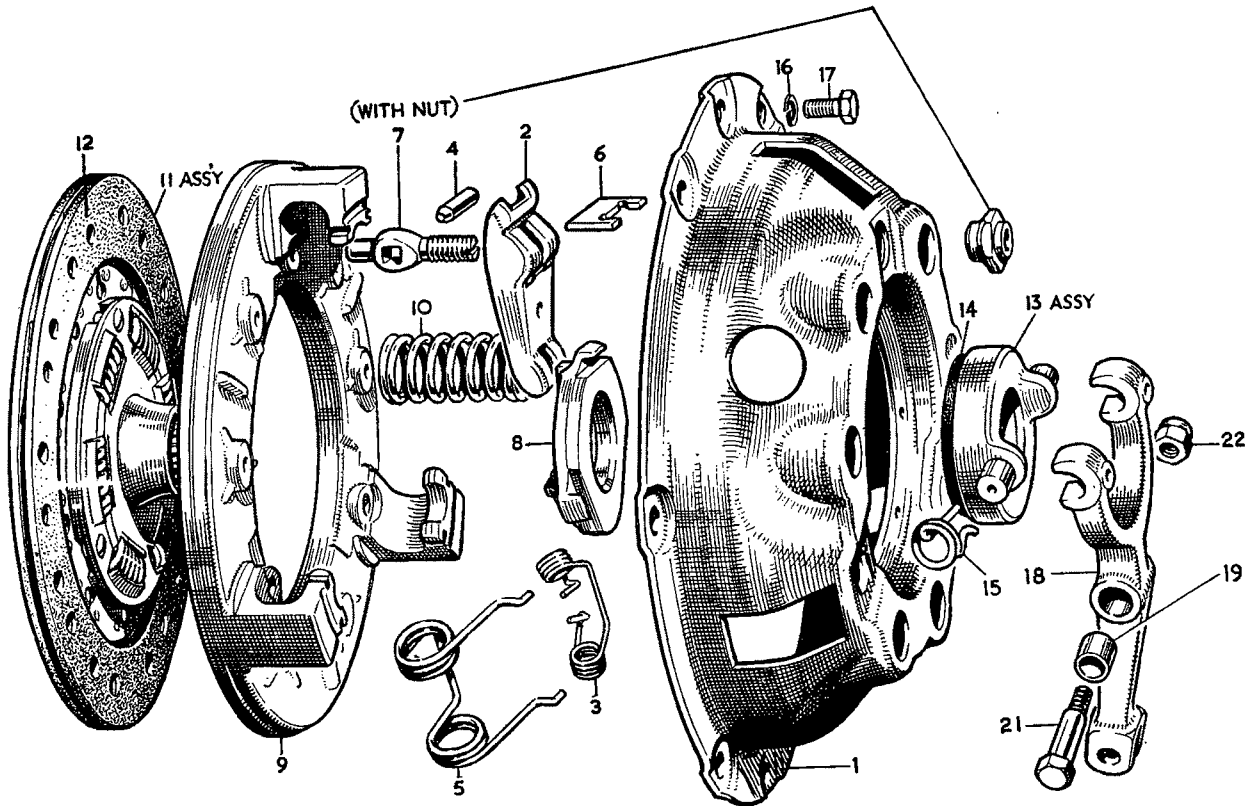

KEY TO THE CLUTCH COMPONENTS

No.	Description	No.	Description	No.	Description
1.	Cover—clutch.	8.	Plate—bearing thrust.	15.	Retainer.
2.	Lever—release.	9.	Plate—pressure.	16.	Washer—spring—cover screw.
3.	Retainer—lever.	10.	Spring—pressure plate.	17.	Screw—cover to flywheel.
4.	Pin—lever.	11.	Plate assembly—driven.	18.	Lever assembly—withdrawal.
5.	Spring—anti-rattle.	12.	Lining.	19.	Bush.
6.	Strut.	13.	Ring assembly—thrust.	21.	Bolt—lever.
7.	Eyebolt with nut.	14.	Ring—carbon.	22.	Nut—bolt.

DESCRIPTION

The clutch is of the single-plate dry-disc type operated hydraulically.

The driven plate assembly

This consists of a splined hub and flexible steel driven plate (C), to the outer diameter of which are fixed the annular friction facings. This plate is attached to the splined hub by a spring mounting which provides a torsional cushion.

Withdrawal bearing assembly

This comprises the graphite release bearing (G) mounted in a cup attached to the throw-out fork and a release plate (H) attached to the inner ends of the release levers (J) by means of the retainer springs (I). Release is accomplished by moving the release bearing forward into contact with the release plate and thus applying pressure to the release levers.

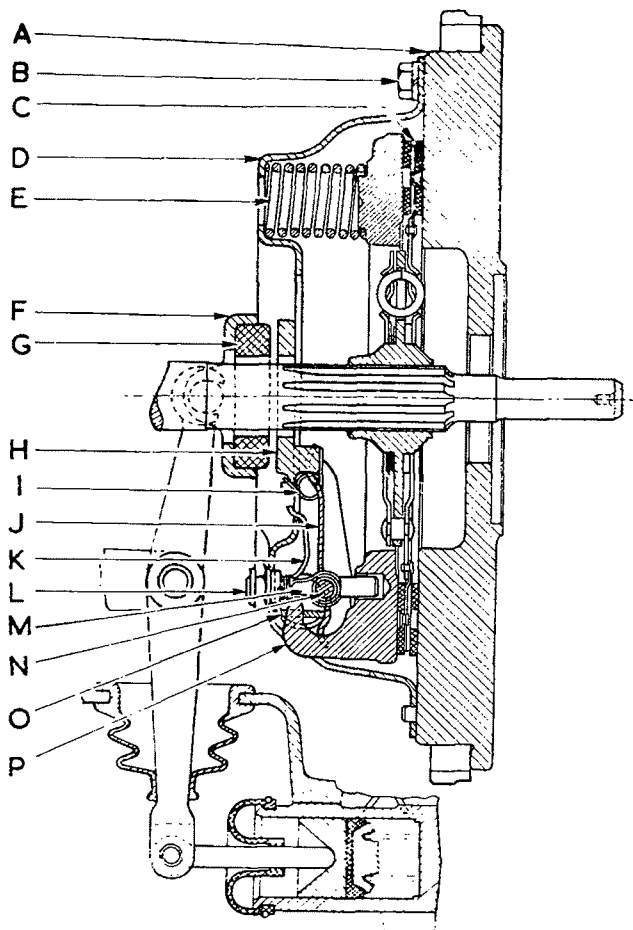

Fig. E.1.
A section through the clutch.

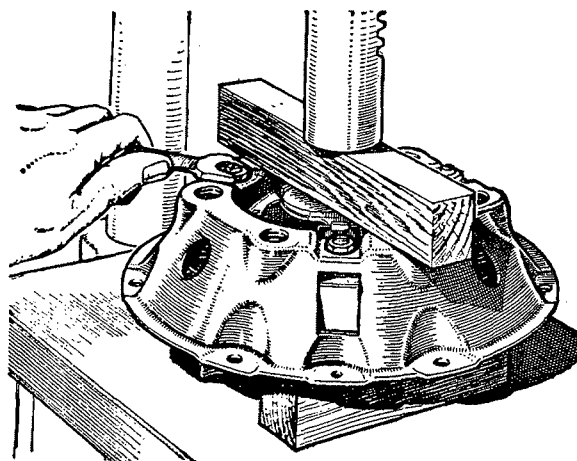

Fig. E.2.

Compressing the springs with wood blocks and press.

Cover assembly

Each release lever is pivoted on a floating pin (N), which remains stationary in the lever and rolls across a short flat portion of the enlarged hole in the eyebolts (M) (see Fig. E.1). The outer ends of the eyebolts extend through holes in the clutch cover and are fitted with adjusting nuts (L) by means of which each lever is located in its correct position. The outer or shorter ends of the release levers engage the pressure plate lugs by means of struts (O) which provide knife-edge contact between the outer ends of the levers and the pressure plate lugs, eliminating friction at this point. Thus the pressure plate (P) is pulled away from the driven plate (C), compressing the six thrust coil springs (E) which are assembled between the pressure plate and the clutch cover (D).

When the foot pressure is removed from the clutch pedal the clutch springs force the pressure plate forward against the driven plate, gradually and smoothly applying the power of the engine to the rear wheels.

Hydraulic operation

A master twin-bore cylinder bolted to the chassis frame contains two pistons operated by the clutch and brake pedals. For clutch withdrawal, fluid pressure is transmitted to the slave cylinder bolted to the clutch housing, moving the piston, push-rod and clutch lever and disengaging the clutch.

The master cylinder

The assembly of the clutch master cylinder is similar to that of the brake master cylinder (Section M) except that no combination inlet and outlet valve is fitted and therefore no pressure is maintained in the clutch line when the pedal is released. (See the illustration on page M.4.)

E

THE CLUTCH

The slave cylinder

This is bolted to the clutch housing and normally requires no maintenance; its assembly is similar to that of the front wheel brake cylinder, and the push-rod is not adjustable.

If the system is drained of fluid it will be necessary to bleed the cylinder after reassembly and refilling.

Section E.1

ADJUSTMENT

It is essential that there should be a clearance between the master cylinder push-rod and the piston when the clutch pedal is released. This clearance, $\frac{1}{32}$ in. (.8 mm.), is adjusted by slackening the locknut and rotating the push-rod in the appropriate direction. Ensure that the pedal is not obstructed by the toeboard or by the floor covering. The free movement at the pedal pad must be sufficient to allow the piston fully to return in the cylinder and still retain the $\frac{1}{32}$ in. (.8 mm.) clearance at the push-rod.

Excessive movement may indicate lack of fluid or the need for bleeding; whenever the system is drained, bleeding will be required after refilling.

Section E.2

REMOVING THE CLUTCH

Remove the power unit as detailed in Section A.18.

Remove the clutch housing bolts and withdraw the gearbox from the engine, taking care to support the gearbox until the first motion shaft is clear of the driven plate and release lever plate.

Loosen each of the hexagon bolts securing the clutch to the flywheel by slackening them a turn at a time until spring pressure is released. The clutch cover can now be disengaged from the flywheel dowels and the whole assembly lifted from the flywheel.

Section E.3

DISMANTLING THE CLUTCH

Two methods are possible in dismantling the clutch:

(a) Using the clutch gauging fixture, and (b) Using a press and blocks of wood.

Using the clutch gauging fixture (Fig. E.6)

Consult the code card to determine the correct spacers for the particular clutch. Place the spacers on the base-plate in the positions indicated on the code card and place the clutch on the spacers. Screw the actuator into the central hole in the base-plate and press the handle

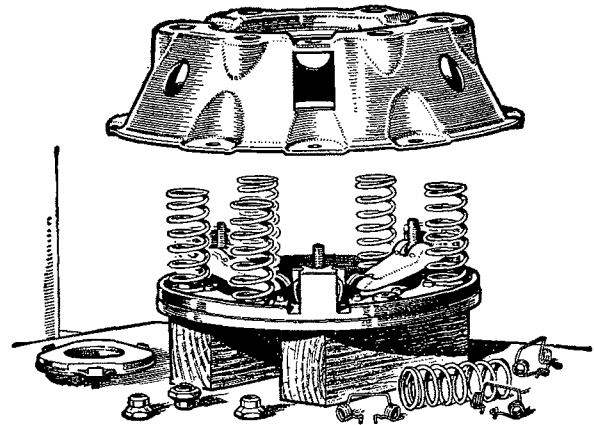

Fig. E.3.

Showing the component parts of the clutch assembly.

to clamp the clutch. Screw the set bolts firmly into the base-plate. The clutch can now be compressed or released as required.

Compress the clutch with the actuator and remove the adjusting nuts gradually to relieve the load of the thrust springs. Lift the cover off the clutch and carry out whatever additional dismantling may be necessary.

Using a press and wood blocks (Fig. E.2)

Place the cover on the bed of a press with the pressure plate resting on wood blocks so arranged that the cover is left free to move downwards. Place a block or bar across the top of the cover, resting it on the spring bosses.

Apply pressure to the cover with the spindle of the press and, holding it under compression, remove the three adjusting nuts. The pressure from the press may now be released gradually until the clutch springs are fully extended.

While stripping down the cover-plate assembly, the parts should be marked so that they may be reassembled in the same relative position to each other, to ensure that the correct balance is maintained. When a new pressure plate is fitted it is essential that the complete cover and pressure plate assembly be accurately balanced, for which reason it is not a practical proposition to fit new pressure plates unless balancing facilities are available.

All parts are available for inspection when the cover is lifted off.

To remove the release levers, grasp the lever and eyebolt between the thumb and fingers so that the inner end of the lever and the threaded end of the eyebolt are as near together as possible, keeping the eyebolt pin seated in its socket in the lever. The strut can then be lifted over the ridge on the end of the lever, making it possible to lift the eyebolt off the pressure plate. It is advisable to replace any parts which show signs of wear.

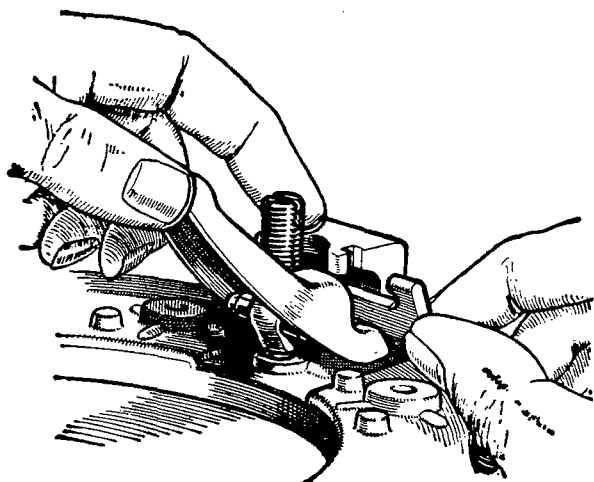

Fig. E.4

To assemble the levers hold the threaded end of the eyebolt and lever close together as shown and insert the struts in the slots of the pressure plate lugs sufficiently to permit the plain end of the eyebolt to be inserted in the hole in the pressure plate

Section E.4

ASSEMBLING THE CLUTCH

Lay the pressure plate on the wood block on the bed of the press (or on the base-plate of the special tool) and place the springs on it in a vertical position, seating them on their small locating bosses. Thoroughly clean all parts and renew any which show appreciable wear.

Assemble the release levers, eyebolts and eyebolt pins, holding the threaded end of the eyebolt and the inner end of the lever as close together as possible. With the other hand insert the strut in the slots of the pressure plate lug just sufficiently to allow the plain end of the eyebolt to be inserted in the hole in the pressure plate. Move the strut upwards into the slots in the pressure plate lugs, over the ridge on the short end of the lever, and drop it into the grooves formed in the lever.

Lay the cover over the parts, taking care that the anti-rattle springs are in position as shown in Fig. E.1 and that the springs are directly under the seats in the cover. Also make sure, if using the original parts, that the eyebolts, eyebolt nuts, pressure plate lugs and cover are fitted in their correct relative positions, as marked when dismantling, to ensure correct balance being maintained.

Compress the springs either by the actuator, if the special tool is being used, or by the use of a wooden block across the cover and a press. Take care to guide the eyebolts and the pressure plate lugs through the correct holes in the cover. Make sure also that the thrust springs remain correctly in their seats.

Replace the eyebolt nuts on the eyebolts and release the pressure compressing the cover assembly.

Section E.5

ADJUSTING THE RELEASE LEVERS

Satisfactory operation of the clutch is dependent upon accurate adjustment of the release levers, so that the pressure plate face is maintained parallel to the flywheel face. This cannot be accomplished by setting the levers parallel to the face of the release bearings after the clutch has been assembled to the flywheel, because of the variations in the thickness of the driven plate.

For accurate adjustment either a gauge plate or the universal gauging fixture must be used.

Using the gauging fixture

After carrying out any necessary servicing, reassemble the parts on the clutch pressure plate, place the cover on it and the whole assembly on the base-plate of the gauging fixture. It is essential that the correct spacers be used, as indicated on the code card.

Bolt the cover to the base-plate and screw the adjusting nuts onto the bolts until the tops of the nuts are flush with the tops of the bolts. Screw the actuator into the base-plate and work the handle a dozen times to settle the mechanism. Remove the actuator. Screw the pillar firmly into the base-plate and place the appropriate adaptor (see code card) on the pillar with the recessed side downwards; place the gauge finger in position.

Turn the adjusting nuts until the finger just touches each release lever, pressing downwards on the finger assembly to ensure that it is bearing squarely on the adaptor. Remove the finger and the pillar and replace the actuator; operate the actuator several times. Re-check with the finger assembly and make any necessary further adjustments.

Lock the adjusting nuts.

Using a gauge plate

Place the gauge on the flywheel in the position normally occupied by the driven plate, and mount the cover assembly on the flywheel in the same position as before dismantling. Tighten the holding screws a turn or two at a time when pulling against the spring pressure, otherwise the cover may be distorted. Before the cover is tightened down be sure that the gauge plate is properly centred and the three flat machined lugs are directly under the levers. The release lever plate must be detached from the levers before the levers are adjusted.

After the cover assembly has been mounted, a short straight-edge should then be laid across the centre boss of the special gauge plate and one nut adjusted until the

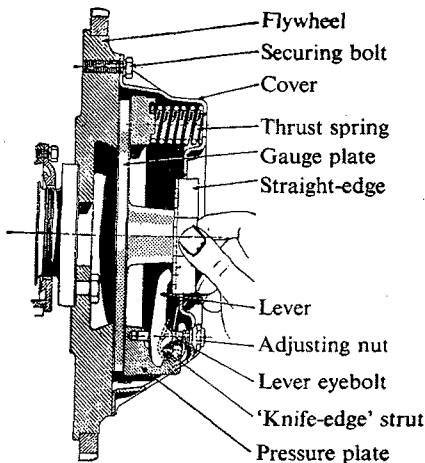

Fig. E.5

Setting the release levers by means of the special gauge plate, Part No. 68886, and a short straight-edge

lever just makes contact with the straight-edge. The other levers can then be set in turn by the same method. If carefully done, this setting will be within the permissible tolerance of .005 in. (.12 mm.).

The adjusting nut is then locked in position by punching the protruding flange of the nut into the slot of the eyebolt, thereby definitely locking it in position. When carrying out this operation take care not to upset the adjustments previously made.

After adjustment is completed, loosen the holding screws a turn or two at a time until the spring pressure is released, which will allow the clutch assembly and the gauge plate to be removed.

Section E.6

REFITTING THE CLUTCH

Position the driven plate assembly on the flywheel, taking care to place the larger-chamfered spline end of the driven plate hub away from the flywheel.

Centralize the driven plate by means of the special alignment bar, Part No. 18G276, which fits the splined bore of the driven plate hub and the pilot bearing in the flywheel. As an alternative a spare first motion shaft can be used.

Locate the cover assembly on the flywheel dowels and secure with the bolts, tightening them a turn at a time by diagonal selection. Do not remove the clutch alignment bar until all the bolts are securely tightened.

Remove the clutch alignment bar and refit the gearbox. The weight of the gearbox must be supported during refitting in order to avoid strain on the shaft and distortion or displacement of the release plate or driven plate assembly.

E.6

Section E.7

SERVICING THE CLUTCH

As the clutch facings wear, the pressure plate moves closer to the flywheel face, and the outer or shorter ends of the release levers follow. This causes the inner or longer ends of the levers to travel farther towards the gearbox. As the release bearing moves rearwards it must result in pushing the piston in the clutch slave cylinder inwards. The piston then forces the excess fluid back into the master cylinder via the compensating orifice.

Provided that the minimum $\frac{1}{32}$ in. (.8 mm.) free movement is maintained between the clutch pedal push-rod and the master cylinder piston, this automatic compensation for wear will always take place.

Should there be no free movement at this point the master cylinder piston will not be allowed to return fully to its stop and therefore the compensating orifice will be cut off.

Excessive pedal movement causes coil binding of the springs and imposes an undue load on the bearing and on the crankshaft, causing excessive and rapid bearing wear. It therefore follows that the required pedal travel is the sum of the two movements:

- (1) *The free movement*, or travel necessary to take up the clearance between the master cylinder push-rod and the master cylinder piston, provided to ensure that the clutch is fully engaged when the foot is removed from the pedal. (See Section E.1.)
- (2) *The effective movement*, or travel necessary to release the clutch, i.e. the amount of effective pedal movement necessary to move the release plate the distance required to free the clutch completely.

If any difficulty is experienced in freeing the clutch when the correct release movement is provided, on no account should efforts be made to improve matters by attempting to increase the effective pedal travel. The actual cause of the trouble must be ascertained and rectified.

To obtain a clean release, the release lever plate should move a distance of $\frac{5}{16}$ in. (8 mm.) towards the flywheel.

Spring pressure

A tolerance of not more than 10 to 15 lb. (4.5 to 6.8 kg.) pressure is allowable on the compression load of the operating springs when at their assembled height, and all clutch springs are tested for this before assembly.

The clutch operating springs are not affected by high clutch temperatures, as the pressure plate absorbs heat rapidly, the springs have only line contact, and a draught is continually passing under them when the engine is running.

Tolerances

Wear on the working faces of the driven plate is about .001 in. (.02 mm.) per 1,000 miles (1600 km.) under normal running conditions. The accuracy of the alignment of the face of the driven plate must be within .015 in. (.38 mm.).

Driven plates

It is important that neither oil nor grease should contact the clutch facings.

Lubrication of the splines of the driven plate is provided at assembly only, when CS881 graphite grease or zinc-based "Keenol" is used.

It is essential to install a complete driven plate assembly when renewal of the friction surfaces is required. If the facings have worn to such an extent as to warrant renewal, then slight wear will have taken place on the splines, and also on the torque reaction springs and their seatings. The question of balance and concentricity is also involved. Under no circumstances is it satisfactory to repair or rectify faults in clutch driven plate centres, and we do not countenance this as manufacturers.

Condition of clutch facings in service

It is natural to assume that a rough surface will give a higher frictional value against slipping than a polished one, but this is not necessarily correct. A roughened surface consists of small hills and dales, only the "high spots" of which make contact. As the amount of useful friction for the purpose of taking up the drive is dependent upon the area in actual contact, it is obvious that a perfectly smooth face is required to transmit the maximum amount of power for a given surface area.

Since non-metallic facings of the moulded asbestos type have been introduced in service the polished surface is common, but it must not be confused with the glazed surface which is sometimes encountered due to conditions to be discussed subsequently. The ideally smooth or polished condition will therefore provide proper surface contact, but a glazed surface entirely alters the frictional value of the facing, and will result in excessive clutch slip. These two conditions might be simply illustrated by comparison between a piece of smoothly finished wood and one with a varnished surface; in the former the contact is made directly by the original material, whereas in the latter instance a film of dry varnish is interposed between the contact surfaces and actual contact is made by the varnish.

If the clutch has been in use for some little time under satisfactory conditions, the surface of the facings assumes a high polish through which the grain of the material can be seen clearly. This polished facing is of light colour when in perfect condition.

Should oil in small quantities gain access to the clutch

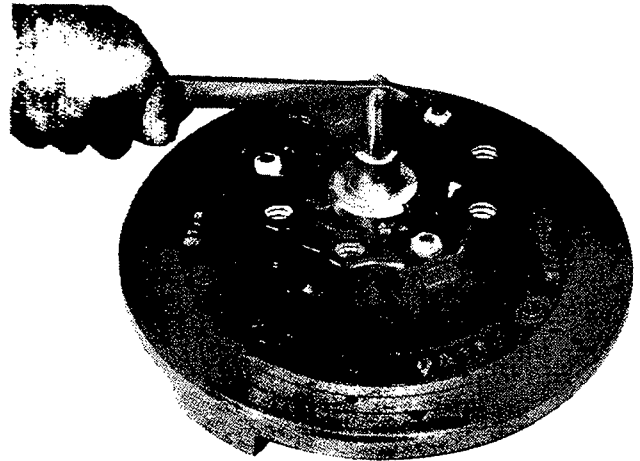

Fig. E.6.

Using the actuator to compress the clutch springs for dismantling or setting the assembly.

and find its way onto the facings, it will be burnt off as a result of the heat generated by the slipping occurring under normal starting conditions. The burning of this small quantity of lubricant has the effect of gradually darkening the facings, but provided the polish of the facing remains such that the grain of the material can be distinguished clearly it has little effect on clutch performance.

Should increased quantities of oil obtain access to the facing, then one of two conditions, or a combination of these, may arise, depending upon the nature of the oil.

1. The oil may burn off and leave a carbon deposit on the surface of the facings, which assume a high glaze, producing further slip. This is a very definite, though very thin, deposit, and in general it hides the grain of the material.
2. The oil may partially burn and leave a resinous deposit on the facings. This has a tendency to produce a fierce clutch, and may also cause excessive "spinning" due to the tendency of the face of the linings to adhere to the surface of the flywheel or pressure plate.
3. There may be a combination of conditions (1) and (2) which produces a tendency to "judder" on such engagement.

Still greater quantities of oil produce a dark and soaked appearance of the facings, and the result will be further slip, accompanied by fierceness or "juddering."

If the conditions enumerated above are experienced, the clutch driven plate should be replaced by a new one. **The cause of the presence of the oil must be traced and removed.** It is, of course, necessary for the clutch and flywheel to be cleaned out thoroughly before assembly.

Where the graphite release bearing ring is badly worn in service, a complete replacement assembly should be

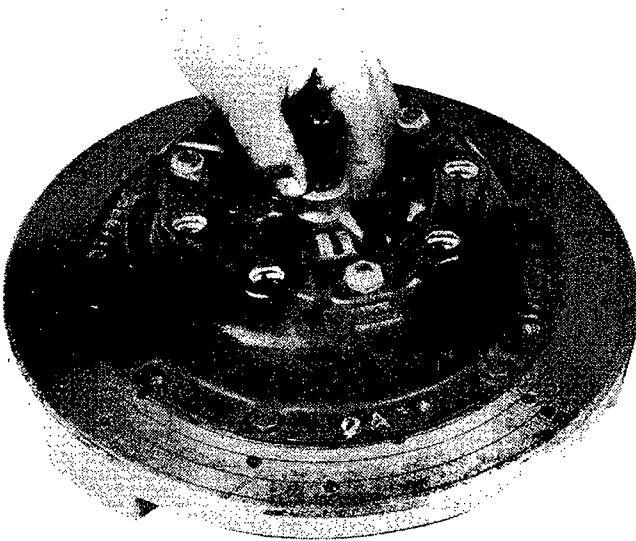

Fig. E.7.

Checking the setting of the release levers.

fitted, returning the old assembly for salvage of the metal cup. These graphite rings are inserted into their metal cup by heating the metal cup to a cherry red, then forcing the graphite ring into position. Immediately the ring is forced into position, the whole should be quenched in oil. Alignment of the thrust pad in relation to its face and the trunnions should be within .005 in. (.12 mm.).

In almost every case of rapid wear on the splines of

the clutch driven plate, misalignment is responsible.

Looseness of the driven plate on the splined shaft results in noticeable backlash in the clutch. Misalignment also puts undue stress on the driven member, and may result in the hub breaking loose from the plate, with consequent total failure of the clutch.

It may also be responsible for a fierce chattering or dragging of the clutch, which makes gear changing difficult. In cases of persistent difficulty it is advisable to check the flywheel for truth with a dial indicator. The dial reading should not vary more than .003 in. (.07 mm.) anywhere on the flywheel face.

Section E.8

CLUTCH WITHDRAWAL LEVER PIVOT BOLT

On later types a modified clutch withdrawal lever pivot bolt (Part No. 11G3196) is fitted. The bolt is increased in diameter and has a shoulder to provide an abutment for the self-locking nut (Part No. LNZ.206) which supersedes the nut and spring washer previously fitted.

A larger bearing bush for the withdrawal lever is needed and so a modified lever (Part No. 11G3193) complete with bush is fitted. The bosses on the front cover (Part No. 11G3197) are modified to take the larger diameter bolt.

The modified parts as a whole can be fitted to earlier vehicles.