

SECTION F

THE GEARBOX

General description.

- Section No. F.1 Removing the gearbox.
- Section No. F.2 Dismantling the gearbox.
- Section No. F.3 Dismantling the third motion shaft.
- Section No. F.4 Assembling the third motion shaft.
- Section No. F.5 Layshaft gear.
- Section No. F.6 Assembling the first motion shaft.
- Section No. F.7 Assembling the rear extension.
- Section No. F.8 Assembling the gearbox.
- Section No. F.9 Modified gearbox front end cover.
- Section No. F.10 Modified gearbox.

THE GEARBOX COMPONENTS

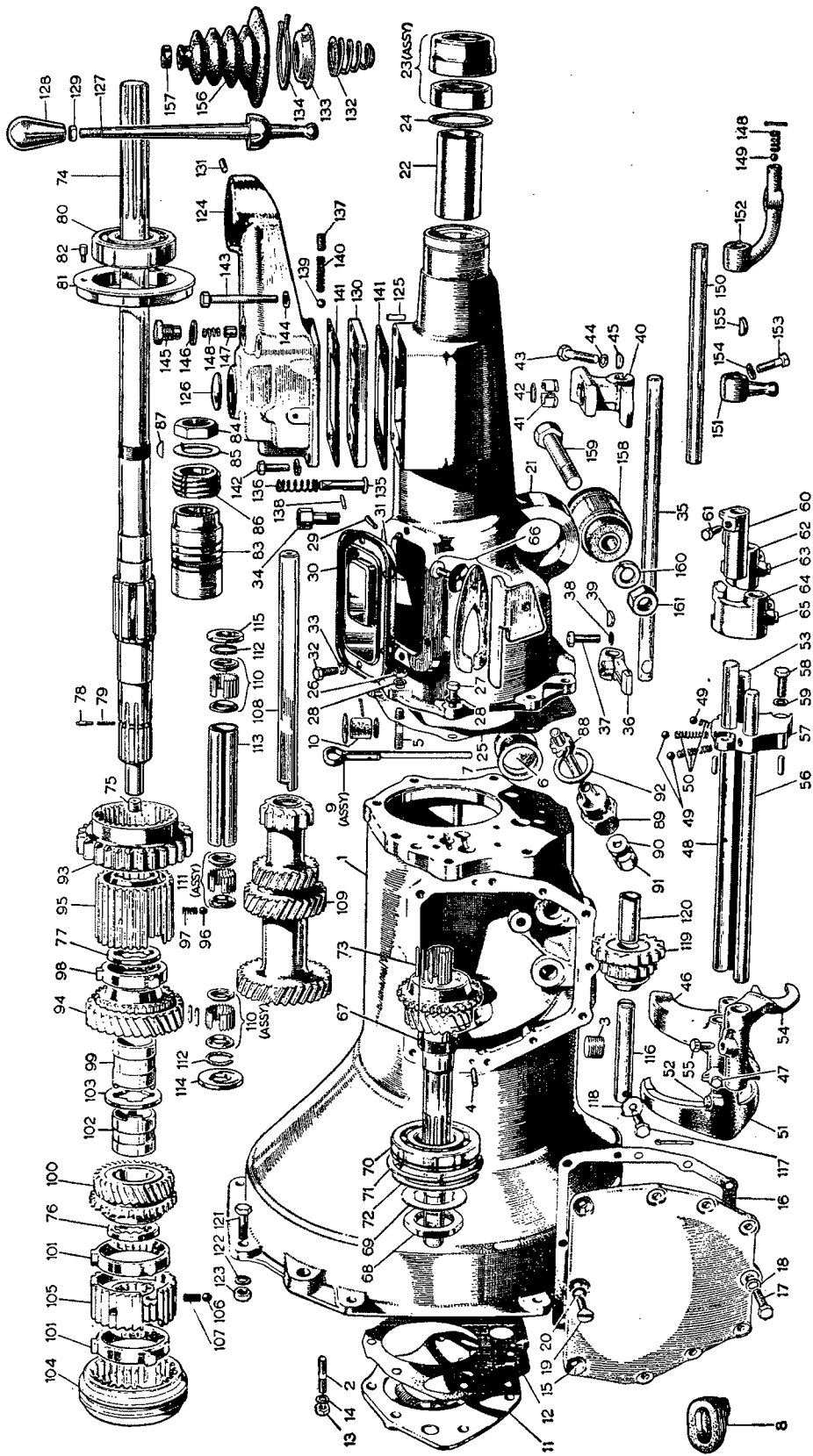

KEY TO THE GEARBOX COMPONENTS

No.	Description	No.	Description	No.	Description	No.	Description
1.	Casing—gearbox.	84.	Nut—shaft and speedometer gear.	122.	Washer—spring.	130.	Stop plate.
2.	Stud—front cover.	85.	Lock washer.	123.	Nut—mounting plate bolt.	131.	Saug—change speed ball.
3.	Plug—drain.	86.	Gear—speedometer drive.	124.	Towel—remote control.	132.	Spring—change speed lever.
4.	Dowel—side cover to gearbox.	87.	Key—gear.	125.	Dowel—remote control tower.	133.	Cover—ball spring.
5.	Stud—gearbox extension.	88.	Pinion—speedometer drive.	126.	Core plug—tower.	134.	Circlip—ball spring cover.
6.	Plug—blanking.	89.	Bush—pinion.	127.	Lever—change speed.	135.	Plunger—reverse selector.
7.	Joint washer—blanking plug.	90.	Oil seal—pinion.	128.	Knob—change speed lever.	136.	Plug—reverse plunger.
8.	Dust cover—clutch withdrawal lever.	91.	Ring—oil seal retaining.	129.	Locknut—change speed lever knob.	137.	Plug—reverse plunger.
9.	Dipstick.	92.	Joint—bush to rear cover.	130.	Stop plate.	138.	Dowel—reverse plunger.
10.	Felt.	93.	Gear—1st speed.	131.	Saug—change speed ball.	139.	Ball—reverse plunger.
11.	Cover—front.	94.	Gear—2nd speed.	132.	Spring—change speed lever.	140.	Spring—reverse plunger detent.
12.	Joint—front cover.	95.	Synchroniser—2nd speed.	133.	Cover—ball spring.	141.	Gasket—control tower.
13.	Nut—front cover studs.	96.	Ball—synchroniser.	134.	Circlip—ball spring cover.	142.	Bolt—short—tower.
14.	Spring washer—front cover stud.	97.	Spring—ball.	135.	Plunger—reverse selector.	143.	Bolt—long—tower.
15.	Cover—side.	98.	Baulk ring—2nd speed gear.	136.	Plug—reverse plunger.	144.	Spring washer.
16.	Joint—side cover.	99.	Bush—2nd speed gear.	137.	Plug—reverse plunger.	145.	Plug—ball retaining—box cover.
17.	Set screw—side cover.	100.	Gear—3rd speed.	138.	Dowel—reverse plunger.	146.	Washer—plug.
18.	Spring washer—side cover screw.	101.	Baulk ring—3rd and 4th gear.	139.	Ball—reverse plunger.	147.	Plunger.
19.	Countersunk screw—side cover.	102.	Bush—3rd speed gear.	140.	Spring—reverse plunger detent.	148.	Spring—plunger.
20.	Shakeproof washer—countersunk screw.	103.	Ring—interlocking—2nd and 3rd bushes.	141.	Gasket—control tower.	149.	Ball—selector lever.
21.	Extension—gearbox.	104.	Coupling—sliding—3rd and 4th speed.	142.	Bolt—short—tower.	150.	Shaft—remote control.
22.	Bush.	105.	Synchroniser—3rd and 4th speed.	143.	Bolt—long—tower.	151.	Lever—front—selector.
23.	Oil seal.	106.	Ball—synchroniser.	144.	Spring washer.	152.	Lever—rear—selector.
24.	Joint washer—oil seal.	107.	Spring—ball.	145.	Plug—ball retaining—box cover.	153.	Set screw—front and rear lever.
25.	Joint extension to gearbox.	108.	Layshaft.	146.	Washer—plug.	154.	Spring washer.
26.	Nut—gearbox extension stud.	109.	Gear unit—layshaft.	147.	Plunger.	155.	Key.
27.	Set screw—gearbox extension.	110.	Bearing—needle roller—layshaft—outer.	148.	Spring—plunger.	156.	Draught excluder—rubber—gear lever.
28.	Spring washer—stud and set screw.	111.	Bearing—needle roller—layshaft—inner.	149.	Ball—selector lever.	157.	Ring—lever draught excluder.
29.	Plug—taper—gearbox extension.	112.	Spring ring—needle rollers.	150.	Shaft—remote control.	158.	Flexible bush—rear engine mounting.
30.	Cover—extension side.	113.	Distance-piece—bearing.	151.	Lever—front—selector.	159.	Bolt—rear mounting bush.
31.	Joint—extension side cover.	114.	Washer—thrust—front.	152.	Lever—rear—selector.	160.	Washer—spring.
32.	Set screw—extension side cover.	115.	Washer—thrust—rear.	153.	Set screw—front and rear lever.	161.	Nut—rear mounting bush bolt.
33.	Spring washer.	116.	Shaft—reverse.	154.	Spring washer.		
34.	Breather assembly.	117.	Screw—locking—shaft.	155.	Key.		
35.	Shaft—remote control.	118.	Lock washer—screw.	156.	Draught excluder—rubber—gear lever.		
36.	Lever—selector—front.	119.	Gear—reverse.	157.	Ring—lever draught excluder.		
37.	Set screw—front lever.	120.	Bush.	158.	Flexible bush—rear engine mounting.		
38.	Spring washer—set screw.	121.	Bolt—gearbox to mounting plate.	159.	Bolt—rear mounting bush.		
39.	Key—selector lever.			160.	Washer—spring.		
40.	Lever—selector—rear.			161.	Nut—rear mounting bush bolt.		
41.	Bush—rear selector lever.						

GENERAL DESCRIPTION

The gearbox has four forward speeds and one reverse. Top gear is obtained by direct drive, third and second by gears in constant mesh, and first and reverse by sliding spur gears.

A sliding joint of the reverse spline type is fitted to the rear end of the third motion shaft and is lubricated from the gearbox.

Section F.1**REMOVING THE GEARBOX**

Remove the power unit as in Section A.18.

Remove the starter motor and unscrew the bolts and nuts securing the bell housing and exhaust pipe support brackets and withdraw the gearbox and rear extension from the engine. Take care to keep the gearbox flange parallel with the crankcase face until the first motion shaft is clear of the clutch.

Section F.2**DISMANTLING THE GEARBOX**

Extract the dipstick, drain plug and speedometer drive.

Unscrew the nuts and remove the gear lever remote control tower and joint washer.

Unscrew and remove the six bolts and the rear extension cover and joint washer. Remove the interlock arm and bracket.

Remove the one nut and seven set screws securing the gearbox extension to the gearbox. Pull the extension from the gearbox, at the same time manoeuvring the remote control shaft selector lever from the selectors.

Unscrew the three countersunk screws and the seven hexagon-headed set screws holding the gearbox cover; remove the cover and overshoot stop.

Cut the locking wire and unscrew the three change speed fork set screws.

Unscrew the two set screws and remove the shifter shaft locating block with shifter shafts from the gearbox; note the two dowels in the block; take care to catch the three selector balls and springs.

Withdraw the forks from the box in the following order—reverse, top and third, and first and second.

Unscrew the clutch lever pivot nut; screw out the pivot bolt and remove the lever with the thrust bearing.

Unscrew the nuts and remove the gearbox front cover; note the bearing shims between the cover and the bearing. Tap out the layshaft, allowing the gear cluster to rest in the bottom of the box.

Unscrew the retaining set screw and remove the reverse shaft and gear.

Withdraw the mainshaft assembly to the rear.

Withdraw the first motion shaft complete with 18 spigot needle rollers, using tool No. 68894 if necessary.

Lift out the layshaft gear cluster and the two thrust washers.

Rear extension

Release the front and rear selector levers from the remote control shaft by removing the clamping screws and sliding the levers from the rod. Extract the keys from the shaft and withdraw the remote control shaft from the rear extension.

Section F.3**DISMANTLING THE THIRD MOTION SHAFT**

Remove the following items in this order: baulk ring; synchromesh sleeve and hub; second baulk ring. If the synchromesh sleeve is removed from the hub take care not to lose the three locating balls and springs which will be released in consequence.

Press down the third speed gear cone thrust washer plunger; rotate the thrust washer to align its splines with those on the shaft and remove the washer.

Withdraw the third speed gear and its splined bush.

Withdraw the bush interlocking washer to release the second speed gear with its bush and baulk ring.

Remove the thrust washer from the splines on the shaft and withdraw the first and second speed hub and gear; if necessary slide the gear from the hub, taking care not to lose the three balls and springs.

Tap up the locking tab and unscrew the rear retaining nut; withdraw the washer, speedometer drive gear and key and the distance sleeve from the shaft.

Press the rear bearing and housing from the shaft.

Section F.4**ASSEMBLING THE THIRD MOTION SHAFT**

Assemble from the front end.

1. Locate the rear thrust washer on the front end of the splines, ground face to the front.
2. Push the longer brass bush up to the splines with the dog towards the front.

Note.—This bush must be fitted so that the oil hole is in line with the one in the shaft and the cut-away portion of the third speed splined bush will be over the locating peg hole when the dogs of the two bushes are engaged with the bush interlocking washer.

3. Fit the second speed baulk ring and gear onto the bush with the plain side of the gear towards the front.
4. Slide on the bush interlocking ring and the shorter

splined bush, locating the dogs of both bushes in the interlocking ring.

- (5) Insert the spring and locating peg into the hole in the shaft.
- (6) Fit the third speed gear onto the bush with the cone towards the front.
- (7) Thread on the front thrust washer, machined face towards the gear, while holding down the locating peg with a thin punch through the hole in the gear cone, and push the washer over it; turn the washer to allow the locating peg to engage in one of the splines.
- (8) Fit the three springs and balls to the third speed synchronizer and push on the synchronizer sleeve (striking dog).
- (9) Push on the top and third gear synchromesh assembly hub with its two baulk rings. The plain side of the hub faces the rear.

Assemble the following items from the rear:

- (1) Insert the three balls and springs in the second gear hub and push the synchronizer sleeve (striking dog) into position on the hub.
- (2) Fit the first speed gear and synchromesh hub assembly, and the baulk ring, to the splines on the shaft.
- (3) Press the rear bearing into its housing and fit it to the shaft, outer flange of the housing to the rear.
- (4) Push on the distance sleeve, speedometer drive gear and key, lock washer and nut.

Section F.5

LAYSHAFT GEAR

The assembly sequence of the layshaft bearings is as follows: a circlip at the rear, a needle race, a single long distance tube, a circlip, a needle race, a circlip, a needle race, a circlip, two races being fitted at the front end and one at the rear.

When assembling, fit a circlip to the innermost groove in the gear, pushing it in from the front, or large gear, end.

Hold the layshaft vertically in the vice, stepped end downwards.

Smear the shaft with grease and assemble a roller bearing on the shaft against the vice jaws and then slide the gear cluster over the shaft and the bearing with the large gear downwards.

Remove the shaft from the vice and push the bearing into the gear against the circlip. Fit a retaining circlip and follow with the end roller bearing assembly and retaining circlip.

Slide the distance tube into the other end of the gear, followed by the other end bearing and circlip. Withdraw the shaft from the gear.

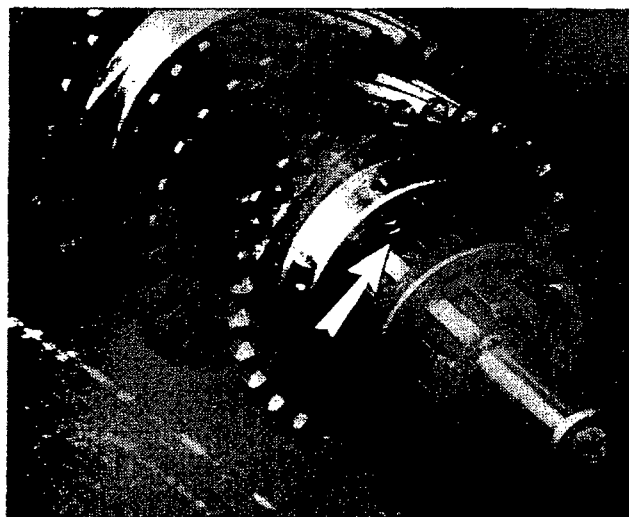

Fig. F.1

The arrow indicates the third speed thrust washer and locating peg. Note the hole in the gear cone

Section F.6

ASSEMBLING THE FIRST MOTION SHAFT

Fit the bearing to the shaft with the spring ring away from the gear. Replace the lock washer and tighten the retaining nut; bend over the locking tab. Fit the shaft to the housing. Do not fit the front end cover until the layshaft has been refitted.

Section F.7

ASSEMBLING THE REAR EXTENSION

Locate the remote control shaft in the rear extension. Fit the front and rear selector levers to the remote control shaft; note that they are secured and located by keys and set screws.

Fit the rear extension to the gearbox, locating the control shaft front selector lever in the shifter rod selectors.

Replace the interlock arm on the rear extension side cover flange and refit the cover.

Section F.8

ASSEMBLING THE GEARBOX

Place the layshaft gear in the box complete with end thrust washers but do not fit the shaft.

Assemble and replace the first motion shaft, and replace the 18 needle-roller bearings.

Insert the third motion shaft from the rear; use the gasket fitted between the box and rear extension to position the dowel and bearing housing. Push home the

F

THE GEARBOX

shaft, the rear bearing and housing, and enter the spigot in the needle-roller race of the first motion shaft.

Fit the layshaft and thrust washers. Line up the cut-away portion of the front end with the layshaft locating groove in the front cover.

Fit the reverse gear and shaft; tighten and lock the set screw.

Refit the front end cover, replacing the bearing shims that were removed on dismantling.

Refit the clutch lever and fork.

Fit the selectors to the shifter shaft rear ends.

Bolt the shifter shaft locating block to the rear face of the gearbox; replace the balls and springs and insert the shifter shafts.

Position the gear change forks in the box in the following sequence: reverse, first and second, third and top. Push the shifter shafts into the box and through the forks; insert, tighten, and wire up the set screws.

Position the selectors on the rear ends of the shifter shafts; insert, tighten, and wire up the set screws.

Refit the gearbox rear extension.

Locate the change speed gate in the gearbox and fit the side cover, using a new joint as necessary.

Screw in the speedometer drive gear assembly, plugs and breather.

The remote control assembly is fitted to the gearbox, and the gearbox filled with oil, after the power unit is installed in the chassis.

Section F.9

MODIFIED GEARBOX FRONT END COVER

Commencing at Engine No. 7981, and a few earlier gearboxes, a modified gearbox front end cover is introduced. The new cover is fitted with an oil seal to prevent the possibility of oil leaking into the clutch housing. There is also a venting duct in the cover necessitating modified fork rods.

The parts may not be fitted to earlier cars.

The new part numbers are :

Gearbox front end cover	1H3137
Gearbox cover oil seal	1H3138
Reverse fork rod	11G3137

First and second fork rod 11G3079

Third and fourth fork rod 11G3140

Refitting the front cover

It is essential that the front cover should be concentric with the first motion shaft in order to avoid oil leaks. This is effected as follows.

Mount the cover, less oil seal, onto the gearbox, and push right home on the studs. Ensure that the cover is free to move in all directions on the studs. If not, the points at which the holes bind on the studs must be relieved until the cover is free to 'float'. Remove the cover and refit the oil seal, using Service tool 18G134 with adaptor 18G134Q.

Fit Service tool 18G598 to the bore of the front cover, and push it in until it is tight. Lightly oil the seal, and carefully fit the front cover, retaining the centralizer 18G598 firmly in position. Fit all spring washers and nuts and tighten them finger-tight only. Using a suitable socket spanner, tighten all nuts, by diametric selection, one half-turn at a time until the nuts are fully tightened. Remove the centralizer.

Section F.10

MODIFIED GEARBOX

Coincident with the introduction of the 15GD series power unit (see Section A.44) the following changes have been incorporated in the gearbox.

The main gearbox casing has been modified to accommodate the new high position of the starter motor on the engine. The gearbox extension has also been changed to suit the new gearbox third motion shaft. The propeller shaft (see Section G.8) is now bolted to a flange which is splined to the gearbox third motion shaft and secured by a nut and spring washer. This arrangement supersedes that of the splined sliding joint for the propeller shaft on the third motion shaft.

To remove the gearbox remove the power unit as in Section A.44. Detach the gearbox from the engine as in Section F.1.

The new gearbox is not interchangeable with that previously fitted.

THE GEARBOX AND REMOTE CONTROL IN SECTION

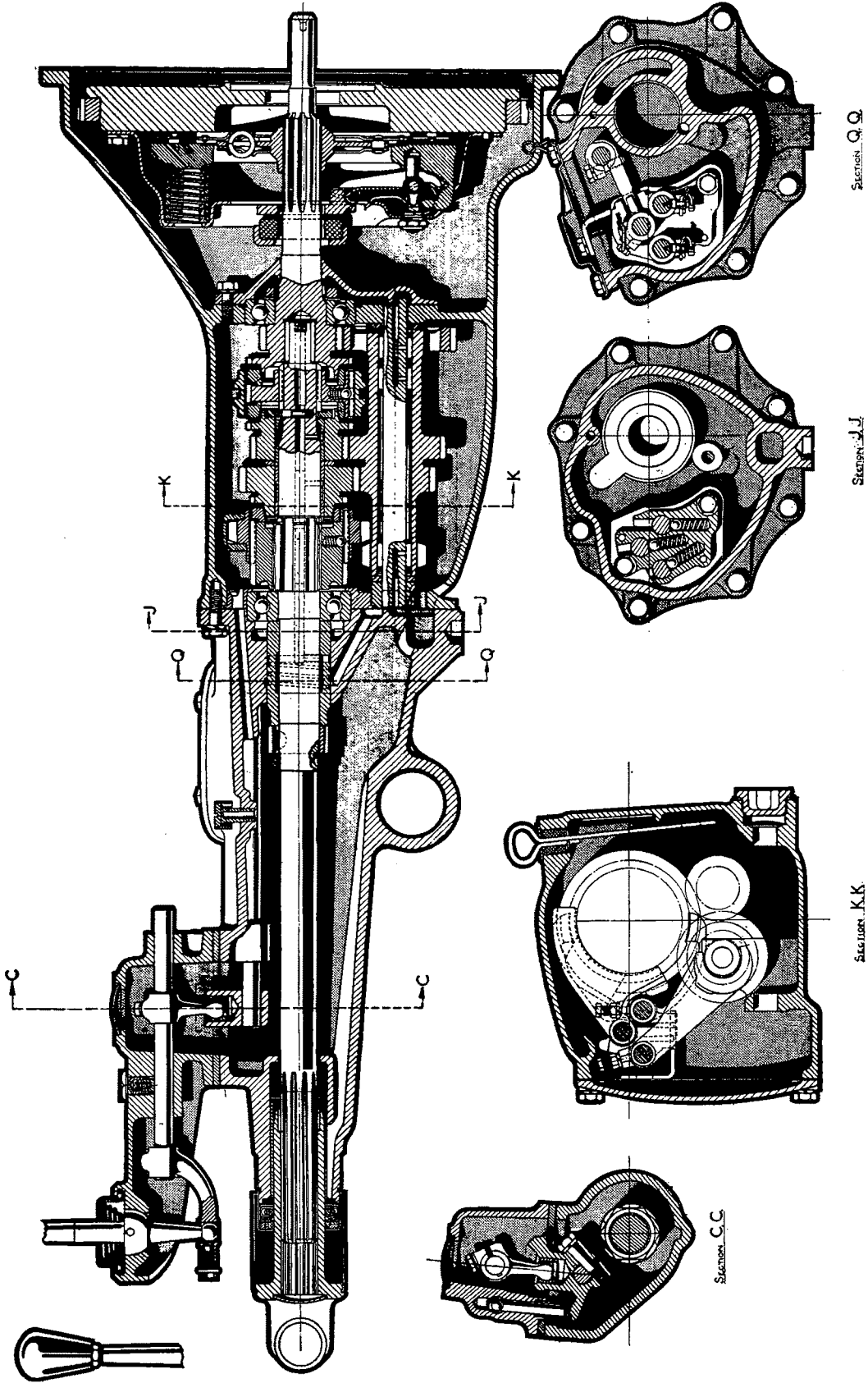



SECTION FF

THE GEARBOX

(MGA 1600 and MGA 1600 [Mk. II])

Section FF.1 Modified gearbox assemblies.

Section FF.1

MODIFIED GEARBOX ASSEMBLIES

Three modifications to the gearbox have been introduced to prevent automatic disengagement of third gear. If trouble of this nature is experienced remove the gearbox from the car (Section F.1) and check the following points:

- (1) Follow the gearbox dismantling procedure given in Section F.2 as far as removing the shift shaft locating block from the gearbox casing. Remove the third and fourth gear shifting rod from the locating block, being careful to catch the ball and spring that will be released. The free length of this spring should be 1.187 in. (30.16 mm.) and the poundage should be between 18 and 20 lb. (8.16 and 9.07 kg.) when the spring is compressed to .75 in. (19.05 mm.). As these springs adopt a permanent set in service without necessarily affecting the poundage, it is advisable to ensure that the spring is in order by checking its poundage.
- (2) Check the depth of the bore in the fork rod locating block, using a depth gauge micrometer. This dimension should be 2.094 in. (53.18 mm.) (see [A], Fig. FF.1). On unmodified gearboxes the depth was 2.157 in. (54.77 mm.). In such cases fit a packing washer .063 in. thick (1.59 mm.) in the bottom of the bore.
- (3) Check the depth of the detent notches in the third and fourth speed selector fork rod. Give particular

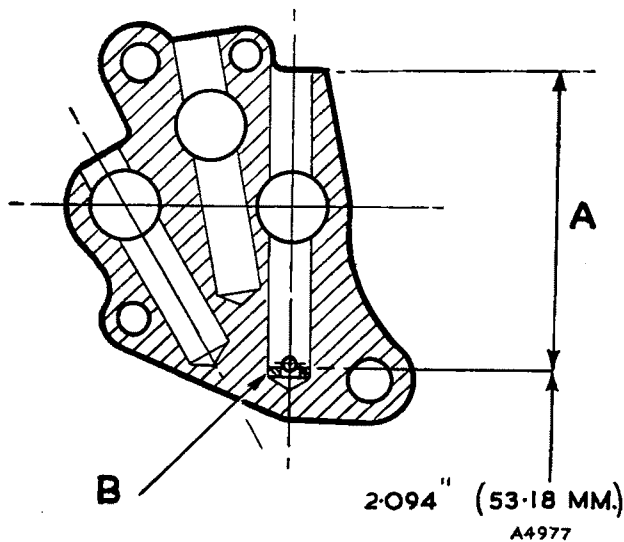

Fig. FF.1

The fork locating block in section, showing a washer (B) .063 in. (1.59 mm.) thick fitted to provide the revised bore depth (A) of 2.094 in. (53.18 mm.)

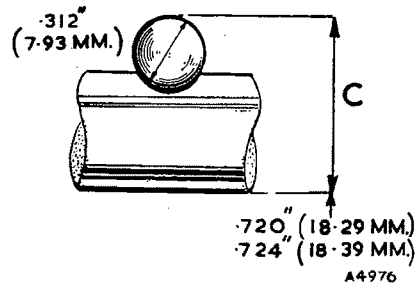

Fig. FF.2

The third and fourth speed fork rod with detent ball placed in a notch for measurement of distance (C)

attention to the third speed notch nearest the centre of the rod. It is not intended that the smaller central (neutral position) notch should be included in this check. Measure the diameter of the detent ball, using a micrometer (Fig. FF.2). Place the ball in each of the deeper notches in turn and measure the distance (C) (Fig. FF.2). If this measurement is greater than .724 in. (18.39 mm.) a new fork rod providing dimension (C) in both the third and fourth speed notches should be selected and fitted. The depth of these two detent notches was increased by .018 in. (.46 mm.) on later gearboxes to give the dimension shown in Fig. FF.2.

- (4) Following the procedure given in Section FF.2, remove the third motion shaft (mainshaft) assembly from the gearbox. Remove the top and third gear synchronism sleeve and hub with its baulk rings. Press down the third speed thrust washer locating plunger. Turn the thrust washer to align its splines with those on the shaft and remove the washer. Withdraw the third speed gear and its bronze bush. Withdraw the bush interlocking washer to release the second speed gear with its bronze bush and baulk ring. Check with a micrometer the outside diameter of the bronze bushes. This should be 1.3115 to 1.312 in. (33.308 to 33.321 mm.). Ensure that this dimension is constant throughout the length of each bush. If the bushes are worn fit new phosphor-bronze bushes (Part Nos. 11G3028 and 11G3029). These were reintroduced at Gearbox No. 24001 to replace the sintered bronze bushes used previously.

Reassemble the third motion shaft (mainshaft), following the instructions given in Section F.4, and immerse the bronze bushes in warm oil to facilitate fitting.

Reassemble the gearbox, using the method given in Sections F.4 and F.5.