

SECTION Q

SPECIAL TOOLS

Every Distributor servicing the M.G. (Series MGA) is recommended to maintain the special tools detailed in this list, as by their use damage to parts will be avoided and repairs generally will be greatly facilitated. For additional information refer to the Service Tool Catalogue (Part No. AKD770). When ordering service tools always quote the new part numbers.

<i>Description</i>	<i>Original Part No.</i>	<i>New Part No.</i>
Engine and clutch		
Exhaust valve seat finishing cutter	301079	18G25
Exhaust valve seat glaze breaker	—	18G25A
Exhaust valve seat top narrowing cutter	301080	18G25B
Inlet and exhaust valve seat bottom narrowing cutter	301081	18G25C
Valve seat cutter handle	301076	18G27A
Valve seat cutting tool fibre box	AJE5012	18G27B
Inlet valve seat top narrowing cutter	—	18G28B
Inlet valve seat bottom narrowing cutter	—	18G28C
Valve suction tool	—	18G29
Valve spring compressor	—	18G45
Piston ring compressor	—	18G55A
Water pump bearing remover and replacer	GT60	18G60
Oil pump relief valve grinding-in tool	—	18G69
Starting dog nut spanner	GT98	18G98
Clutch assembly gauging fixture	AJA5010	18G99A
Camshaft liner reamer (basic tool)	AJE5001	18G123A
Camshaft liner reamer cutter	—	18G123B
Camshaft liner reamer cutter	—	18G123E
Camshaft liner reamer cutter	—	18G123F
Camshaft liner reamer pilot	—	18G123L
Camshaft liner reamer pilot	—	18G123T
Camshaft liner reamer pilot	—	18G123AB
Camshaft liner reamer pilot	—	18G123AC
Camshaft liner reamer pilot	—	18G123AD
Fibre box	—	18G123AL
Camshaft liner remover and replacer (basic tool)	AJA5060	18G124A
Camshaft liner remover adaptor	—	18G124B
Camshaft liner remover adaptor	—	18G124C
Camshaft liner remover adaptor	—	18G124F
Camshaft liner remover adaptor	—	18G124H
Inlet valve seat finishing cutter	—	18G174
Inlet valve seat glaze breaker	—	18G174A
Valve seat cutter pilot	18G31	18G174D
Valve rocker bush remover and replacer	—	18G226
Clutch plate centralizer	67833	18G279
Impulse extractor—UNF.	301203	18G284
Main bearing cap removal adaptor	AJH5147	18G284A
Valve suction tool	66893	18G328

SPECIAL TOOLS

<i>Description</i>	<i>Original Part No.</i>	<i>New Part No.</i>
Gearbox		
Bearing and oil seal replacer adaptor handle (basic tool)	—	18G134
Gearbox extension oil seal replacer adaptor	—	18G134M
Gearbox extension oil seal replacer adaptor	—	18G134N
Gearbox front cover oil seal replacer	—	18G134Q
Synchromesh unit assembly ring—second speed	AJA5055	18G222
Synchromesh unit assembly ring—third speed and top	AJA5056	18G223
Dummy layshaft	AJA5057	18G266
Oil seal remover (basic tool)	—	18G389
Oil seal remover adaptor	—	18G389B
Gearbox front cover centralizer	—	18G598
Front suspension and steering		
Front and rear hub plate remover (basic tool)	AJA5019	18G304
Bolt adaptor— $\frac{7}{16}$ in. UNF.	AJA5021	18G304B
Steering-wheel remover	68827	18G310
Steering tie-rod pin spanner	68965	18G312
Steering tie-rod 'C' spanner	300813	18G313
Wire wheel hub remover.. .. .	—	18G363
Rear axle and rear suspension		
Bevel pinion flange wrench	AJA5062	18G34A
Differential bearing remover (basic tool)	AJA5061	18G47C
Differential bearing remover adaptors	—	18G47T
Bearing and oil seal replacer adaptor handle (basic tool)	—	18G134
Rear hub bearing remover, differential bearing replacer, and rear hub assembly replacer adaptor	—	18G134P
Bevel pinion and differential bearing setting gauge	—	18G191B
Bevel pinion bearing outer race remover (basic tool)	—	18G264
Bevel pinion bearing outer race remover adaptor	—	18G264E
Bevel pinion bearing outer race remover adaptor	—	18G264F
Partitioned fibre box	—	18G264K
Rear hub nut spanner	—	18G152
Bevel pinion bearing preload gauge	—	18G207
Bevel pinion inner race remover and replacer	—	18G285
Front and rear hub plate remover (basic tool)	AJA5019	18G304
Bolt adaptor— $\frac{7}{16}$ in. UNF. (2 off)	AJA5021	18G304B
Hub remover thrust pad adaptor	AJA5146	18G304J
Wire wheel hub remover.. .. .	—	18G363
Body		
Body jack and metal case	—	18G308B
Miscellaneous		
Lockheed bleeder screw wrench	46746	18G353
Torque wrench	AJE5010	18G372

SPECIAL TOOLS



18G25. Exhaust Valve Seat Finishing Cutter

Use with pilot 18G174D and handle 18G27A.

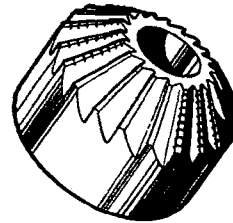

18G25

18G25A. Exhaust Valve Seat Glaze Breaker

Use with pilot 18G174D and handle 18G27A.

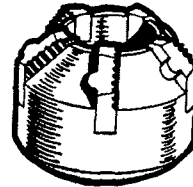

18G25A

18G25B. Exhaust Valve Seat Top Narrowing Cutter

Use with pilot 18G174D and handle 18G27A.

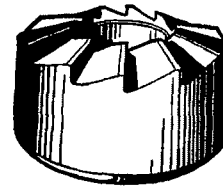

18G25B

18G25C. Inlet and Exhaust Valve Seat Bottom Narrowing Cutter

Use with pilot 18G174D and handle 18G27A.

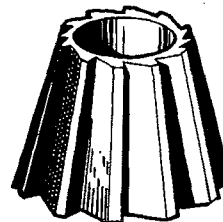

18G25C

18G27A. Valve Seat Cutter Handle

A standardized type of handle for use with a wide range of cutters. A spanner can be used on the square end when cutting valve seats on models where the tommy bar will foul the engine bulkhead.

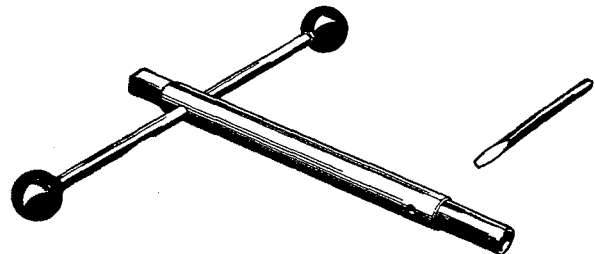

18G27A

18G28B. Inlet Valve Seat Top Narrowing Cutter

Use with pilot 18G174D and handle 18G27A.

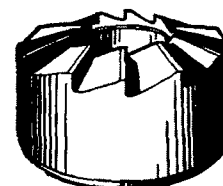

18G28B

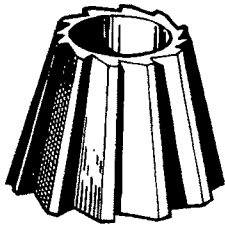

18G28C

18G28C. Inlet Valve Seat Bottom Narrowing Cutter
Use with pilot 18G174D and handle 18G27A.



18G29

18G29. Valve Suction Tool

A handle complete with a detachable suction pad 18G29A; a further suction pad 18G29B is available for use on smaller valves.

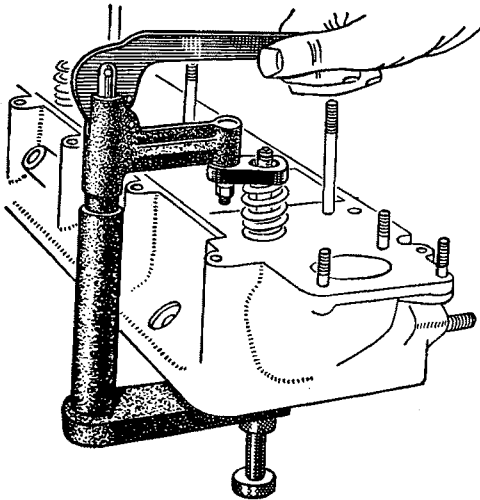

18G45

18G45. Valve Spring Compressor

This tool is designed for overhead-valve engines. It has a cam and lever action and screw adjustment. The adaptor ring is shaped to facilitate the fitting of cotters.

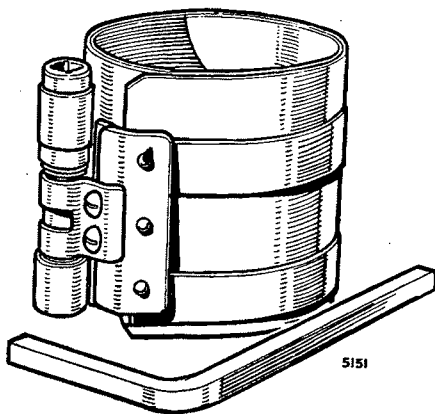

18G55A

18G55A. Piston Ring Compressor

Designed to cover a wide range of pistons, it is easy to operate and will compress the strongest piston ring, making assembly to the bore a quick and easy operation.

SPECIAL TOOLS



18G60. Water Pump Bearing Remover and Replacer

To safeguard against broken pump bodies this specially designed tool should be used when removing and replacing bearings. Comprising a drift, a dummy bearing, and a pilot, it aligns each bearing with its housing before the bearing is pressed into position.

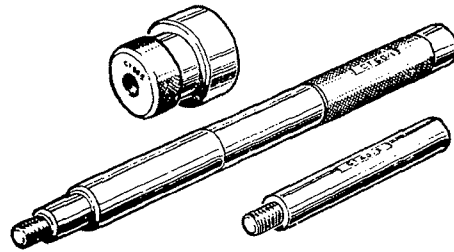

18G60

18G69. Oil Pump Relief Valve Grinding-in Tool

The small knurled knob at the end of this tool is turned to compress the rubber sleeve and increase its diameter until, when pressed into the valve, it will hold it securely while it is lapped to its seat.

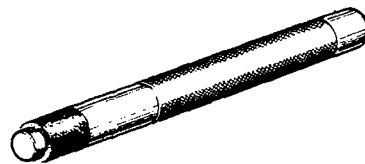

18G69

18G98. Starting Dog Nut Spanner

A 'shock-type' spanner designed to enable the starting dog nut to be removed without locking the crankshaft.

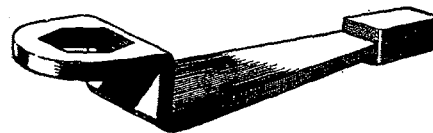

18G98

18G99A. Clutch Assembly Gauging Fixture

This tool provides for accurate adjustment of the levers and, additionally, affords a fixture upon which to dismantle and assemble the unit.

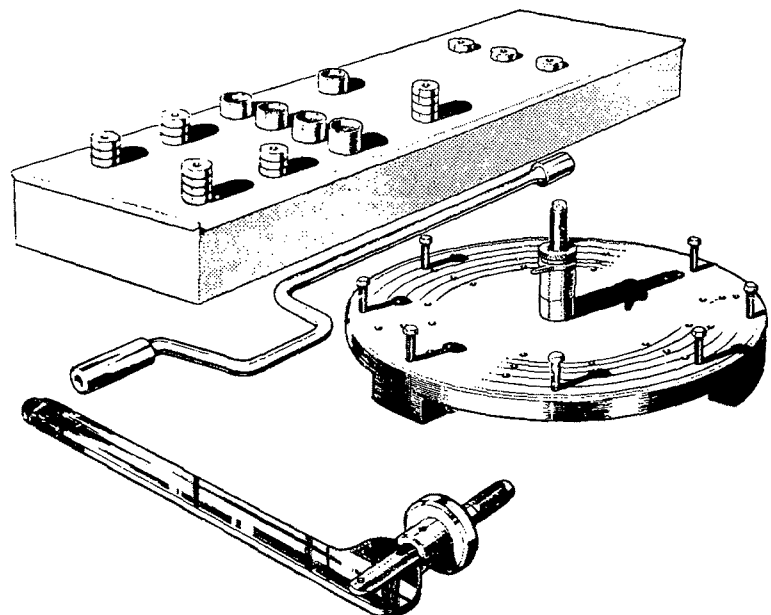

18G99A

SPECIAL TOOLS

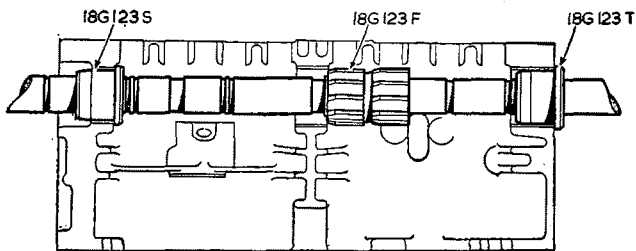
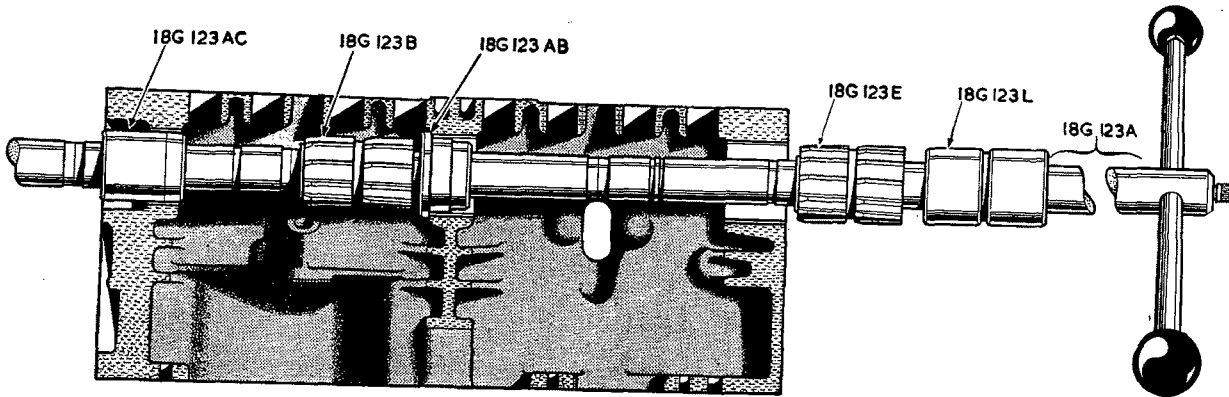

18G123A. Camshaft Liner Reamer (basic tool), Cutters, and Pilots

This equipment is essential when reconditioning cylinder blocks, otherwise camshaft liners cannot be reamed in line, and in consequence the clearance between the camshaft journal and liner will be incorrect. This basic tool must be used with the cutters and pilots supplied separately and shown on this page. Full instructions for using the equipment will be supplied with each basic tool.

18G123B. Camshaft Liner Reamer Cutter

18G123E. Camshaft Liner Reamer Cutter

18G123F. Camshaft Liner Reamer Cutter

18G123L. Camshaft Liner Reamer Pilot

18G123T. Camshaft Liner Reamer Pilot

18G123AB. Camshaft Liner Reamer Pilot

18G123AC. Camshaft Liner Reamer Pilot

18G123AD. Camshaft Liner Reamer Pilot

18G123AL. Camshaft Liner Reamer Component Fibre Box

SPECIAL TOOLS

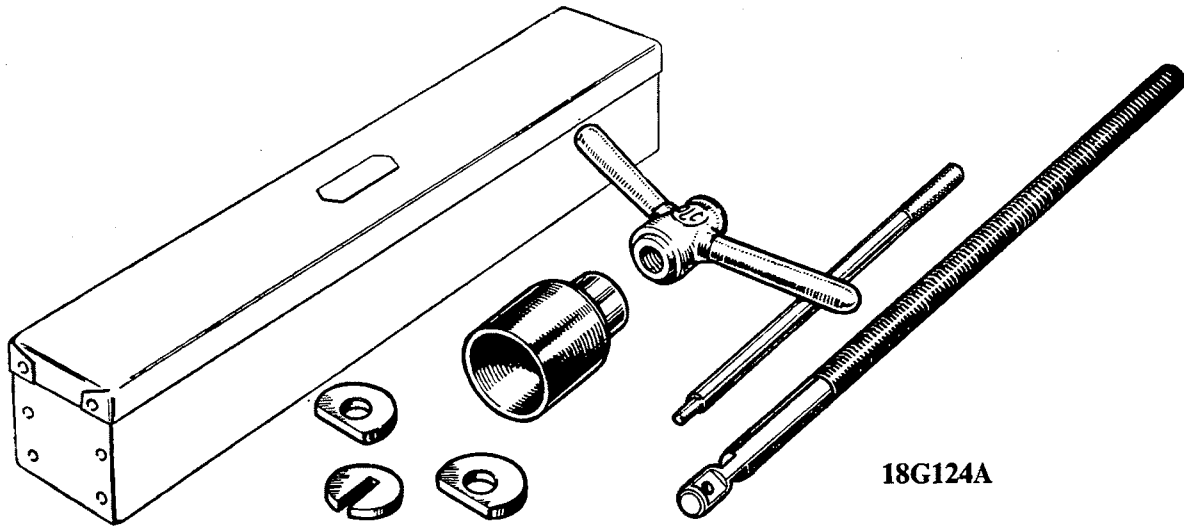

18G124A

18G124A. Camshaft Liner Remover and Replacer (basic tool)

The equipment consists of a basic tool 18G124A and various adaptors (supplied separately) for different types of engines and for this model shown below. Liners can be removed and replaced without the damage invariably associated with the use of improvised drifts. Full instructions for using the equipment will be supplied with each basic tool.

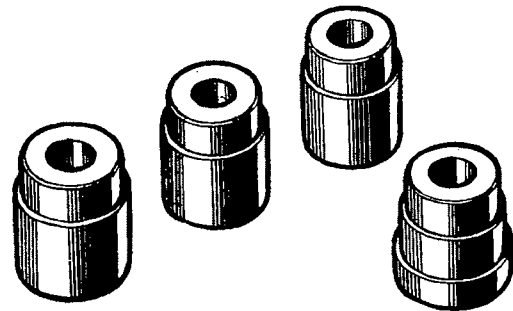

18G124B
18G124C

18G124F
18G124H

18G124B, 18G124C, 18G124F, and 18G124H. Camshaft Liner Remover Adaptors

18G174. Inlet Valve Seat Finishing Cutter

Use with pilot 18G174D and handle 18G27A.

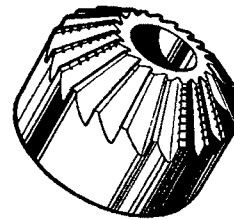

18G174

18G174A. Inlet Valve Seat Glaze Breaker

Use with pilot 18G174D and handle 18G27A.

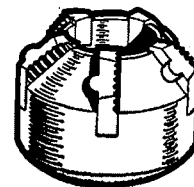

18G174A

18G174D. Valve Seat Cutter Pilot

Use with the cutters listed above and handle 18G27A.

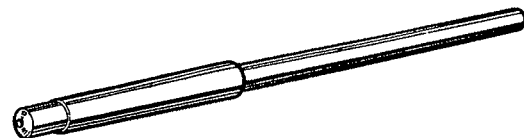

18G174D

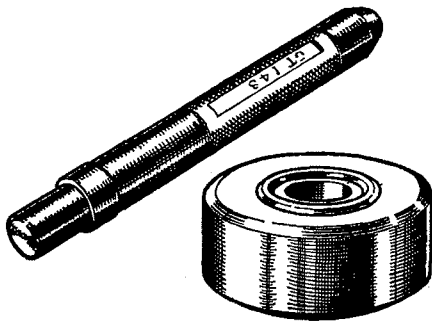

18G226

18G226. Valve Rocker Bush Remover and Replacer

The flange of the driver is recessed to prevent the split bush opening when being driven into position; the anvil is also recessed to retain the rocker during the operation. Use of a light press is desirable when using this tool, alternatively a vice or copper-faced hammer may be used.

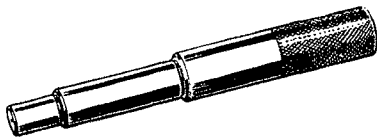

18G279

18G279. Clutch Plate Centralizer

When reassembling the single-plate clutch it is essential to use this tool to ensure that the clutch plate is concentric with the spigot bearing in the flywheel centre, otherwise it is impossible to assemble the gearbox to the engine. This tool will also fit the Wolseley Four-Fifty, Morris Oxford (Series MO), and Morris Six (Series MS) models.

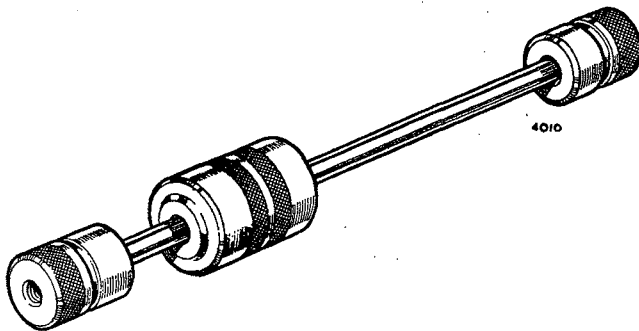

18G284

18G284. Impulse Extractor—UNF.

This universal impulse extractor when used with adaptor 18G284A will remove the main bearing cap.



18G284A

18G284A. Main Bearing Cap Removal Adaptor

The adaptor for use with impulse extractor 18G284.



18G134

18G134. Bearing and Oil Seal Replacer Adaptor Handle (basic tool)

For use with adaptor 18G134M or 18G134N to replace the gearbox extension oil seal.

SPECIAL TOOLS

Q

18G134M and 18G134N. Oil Seal Replacer Adaptors

Used with handle 18G134 for the replacement of gearbox extension oil seals.

For later power units (from Engine No. 10990) use adaptor 18G134N.

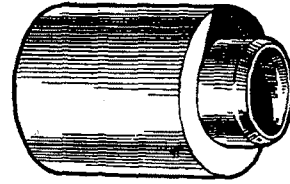

18G134M and 18G134N

Synchromesh Unit Assembly Rings

18G222—Second Speed

18G223—Third Speed and Top

This tool is specially designed to retain the balls and springs in the synchronizer hub while it is being pushed into the sliding sleeve.

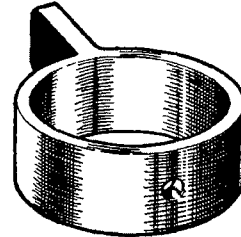

18G222 and 18G223

18G266. Dummy Layshaft

Reassembly of the layshaft into the laygear is greatly simplified by the use of this tool.

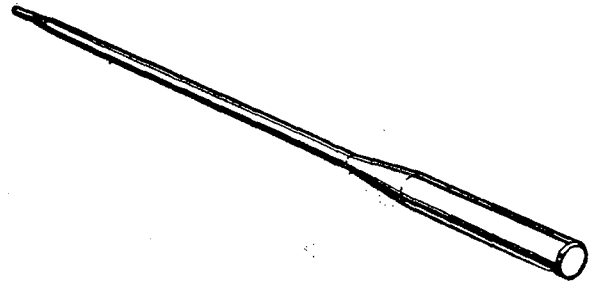

18G266

18G389. Oil Seal Remover (basic tool)

This basic tool together with the appropriate adaptor is essential for removing the gearbox extension oil seal easily and without damage to the extension.

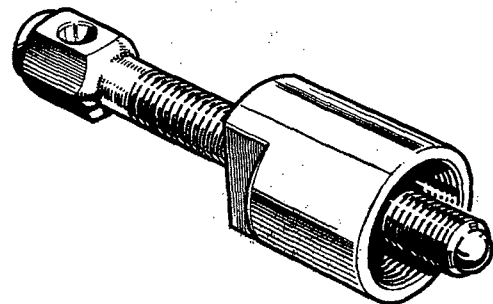

18G389

18G389B. Oil Seal Remover Adaptor

Use with basic tool 18G389.

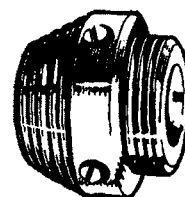

18G389B

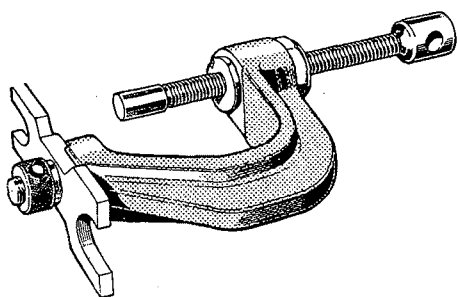

18G310

18G310. Steering-wheel Remover

This extractor has been specially designed to remove the steering-wheel without damage. Dealers who already possess tool 55418 and the attachment (Part No. 56052) will find that this may also be used to withdraw the steering-wheel. It can also be used to extract Wolseley and Morris steering-wheels.

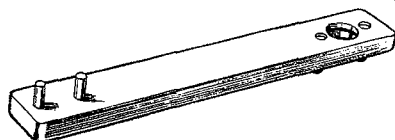

18G312

18G312. Steering Tie-rod Pin Spanner

This tool is designed for use in conjunction with the special spanner 18G313 for dismantling the steering tie-rod ball housing without damage.

In use it is clamped securely in a vice and the two holes of the ball housing are engaged with the two pins of the extractor, pushing the ball housing into the tool as far as it will go. Using the special spanner 18G313, engage the claws with the ball housing cap and unscrew it from the housing.

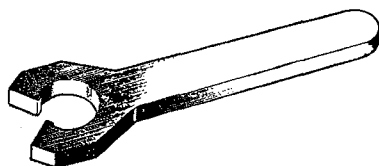

18G313

18G313. Steering Tie-rod 'C' Spanner

A tool with jaws designed to engage the shallow splines of the steering rack ball housing cap and remove it without damage.

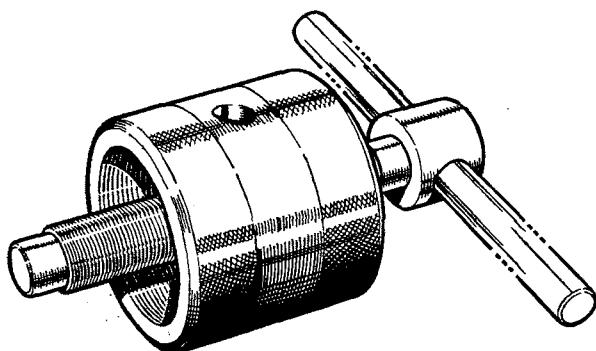

18G363

18G363. Wire Wheel Hub Remover

Designed to withdraw left-hand and right-hand 'knock-on' hubs. The body is internally threaded with a left-hand thread in one end and a right-hand thread in the other.

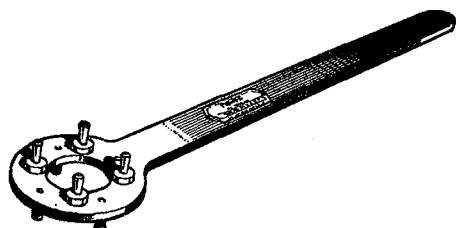

18G34A

18G34A. Bevel Pinion Flange Wrench

Used to hold the bevel pinion flange when unscrewing the flange retaining nut.

